

Water Treatment

Environmentally friendly and sustainable



Merus GmbH
71063 Sindelfingen
Germany

Email: info@merus.de

Online: www.merusonline.com

www.merusoilandgas.com

Figures, Facts and Information

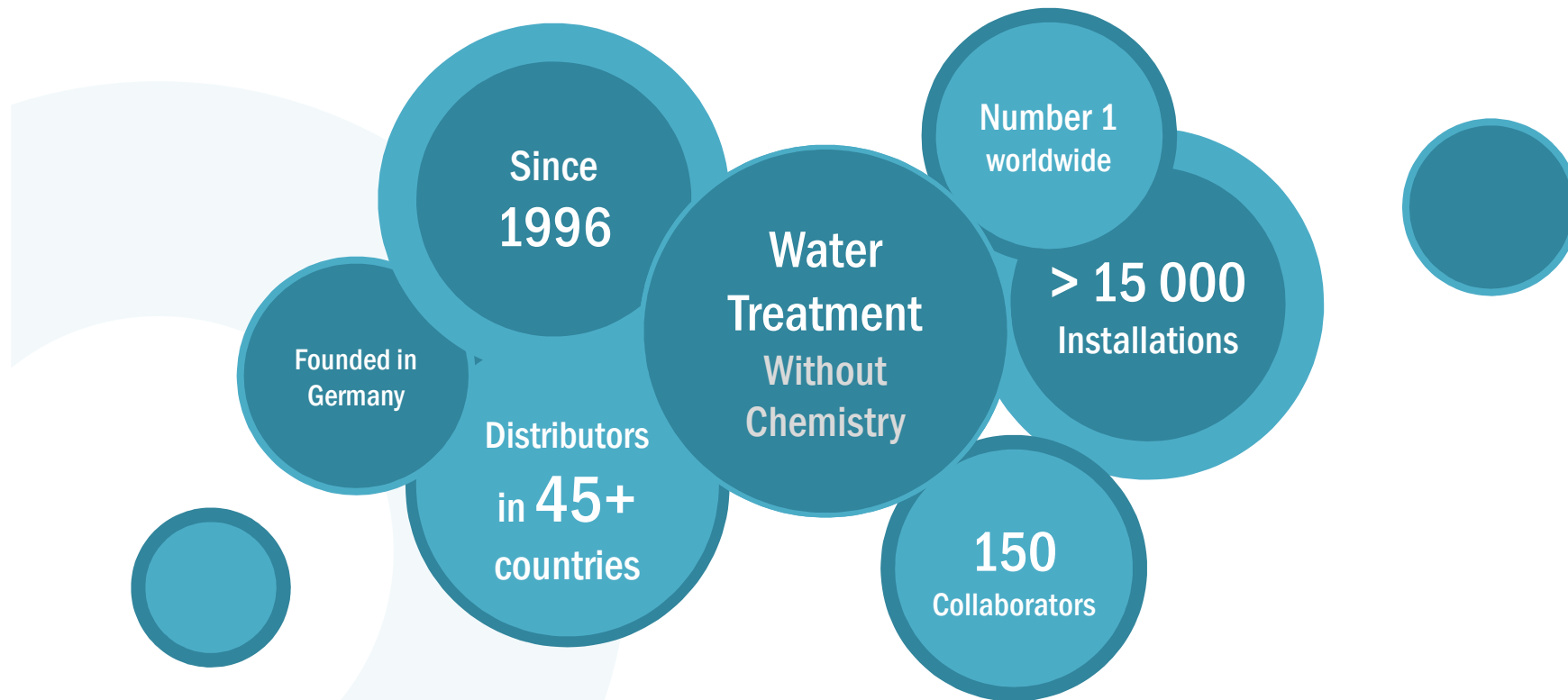

Goal and Philosophy



Goal

Provide treatment of all liquids without chemistry and minimum input of energy and raw material.

Achieve maximum results for the customers benefit mainly in water, crude oil and natural gas.



Philosophy

We believe that respect is the core to sustainable success. This includes both, respecting people and nature.

Basic Information

The Merus Ring is not **changing the chemistry** of the liquids.

but **changes the physical behavior** of the solved and solid ingredients of water.

Thereby it **reduces harmful side effects** the liquid has on pipes and machines.



The Merus Ring

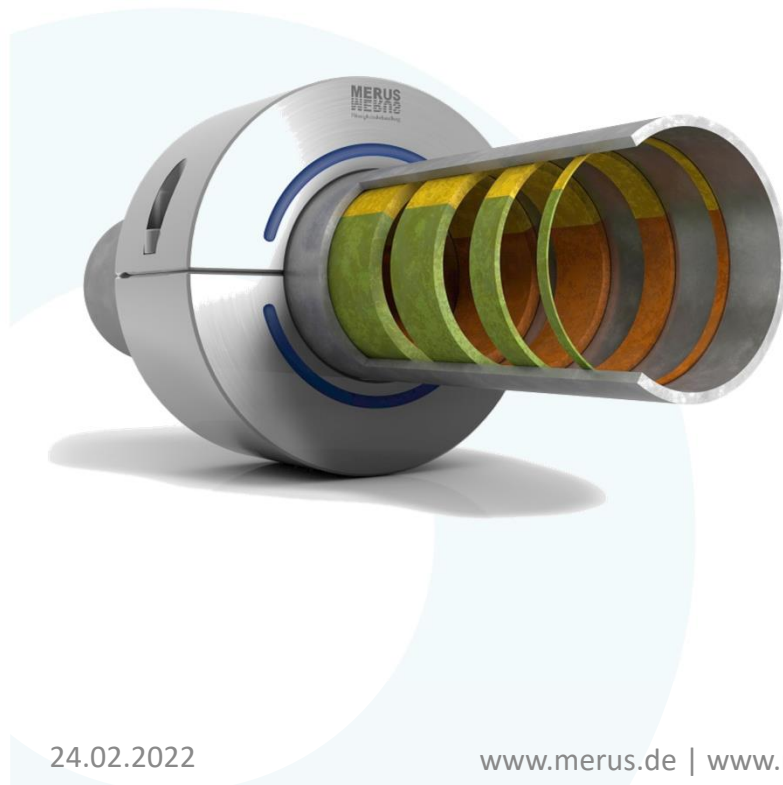

No chemistry

The ring is emitting oscillations which influence the physical behavior of the water.

No additional power supply required

The Merus ring is driven by the ambient temperature.

No effort

Your pipelines don't have to be damaged to install the ring. It is placed around the pipeline without contact to the water.

Fields of activity

Drinking Water

Against **rust and corrosion**

No deposition of **calcium carbonate and soluble salts**

Limits the reproduction of **bacteria** (legionella)

Against **algae** and marine growth

Less **biofouling**

Against problems in **hydro carbon** – Upstream, Midstream, Downstream

Industrial Water

Waste Water

Sea Water

Function and Results

The solubility of all soluble parts in water is increasing..

- no new scale forms
- existing scale is dissolved and washed out

Corrosion:

Less corrosion (< 1 mpy) due to changed physical properties of the water.

Existing corrosion will dissolve and washed out.

Algae and Bacteria:

Without deposit the habitat of algae and bacteria is destroyed and the fertility decreases.

Usually less than 100 CFU (colony forming units) without the use of biocide.



Verification

How to notice and measure the change?

Corrosion

Measuring TDS (Total dissolved solid in ppm) or iron content in the water.

In case of corrosion the amount of iron in the water increases right after the installation of the Merus ring. Shortly after it will decrease below the initial level.

Scaling / fouling

E.g. Heat exchanger: heat transfer, delta t or delta p

Bacteria / Algae / Marine Growth

Idly can be reduced to the amount of micro organism in the feed.



Onsite Trial /
Demonstration
available*

*Depending on the size of the system the demonstration is free or for a small fee covering the costs of the installation



Selected references

EXAMPLE CASES



Heat exchanger in refinery, Saudi Aramco, KSA

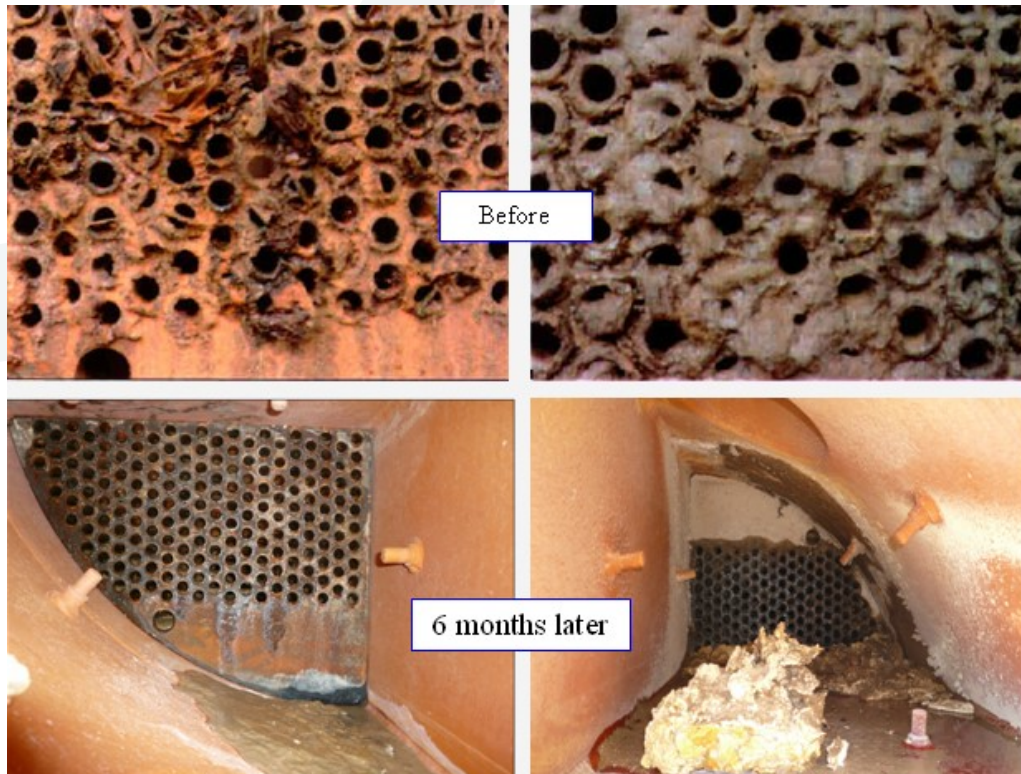

- Treatment of cooling water
- Merus ring is installed before the heat exchangers
- Excellent results could be monitored after 6 months

Heat exchanger in refinery, Saudi Aramco, KSA

→ Monitoring on a six-pass heat exchanger

Upstream of the ring

Untreated



Downstream of the ring

Treated
by Merus



Biofouling in Cooling System, ISO Octane Refinery

- Growing biomass in a dead leg of the cooling system
- Pipes are intended for a planned enlargement of the plant (approx. 6m pipe-end, closed by a flange)
- Installation of several rings all over the system to reach the water in every pipe
- Results could be observed after 8 weeks without further mechanical cleaning
- Until now biofouling doesn't cause problems anymore – corrosion rate stays at a level of <1,5 mpy (before >10)



Sea water scaling in fresh water generator, Hapag Lloyd

- Installation of a Merus ring at the fresh water generator which is used to produce drinking water out of sea water
- Without Merus scale and corrosion, despite the use of chemicals (Picture 1)
- After 6 months with Merus **clean**, without chemicals or mechanical cleaning (Picture 2,3)



Case effluent system, Q8 Refinery in Rotterdam, NL



Before:

Blocking in an effluent pipe through which all kind of water and oil spills flows.

→ Installation of 2 Merus rings for a 12 months paid demo

After treatment with Merus rings:

→ Pipe diameter almost back to normal (from 6" back to 12") – fully operable

→ Service contract ensures continuing success



Reverse osmosis plant

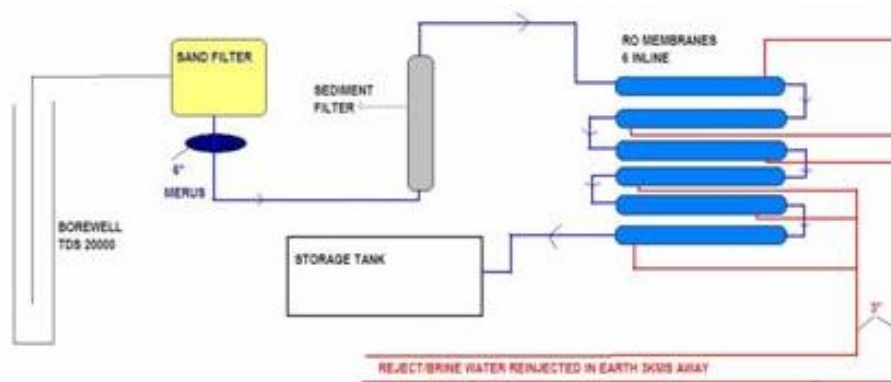

Ground water is used to produce drinking water

Before

High TDS in the water (>5000 ppm) causes scaling.

→ Replacement of sediment filters once a week, membranes every 3 months

After

Installation of Merus ring, adding of chemicals is stopped. After a few days the pressure has stabilized and the production of fresh water stays at the same level.

Cruiser Queen Elisabeth II, Cunard Cruise Lines



Sea water toilet flush

→ Corrosion and scaling cause low pressure at the end of the lines, flushing of the toilets is impossible

Merus rings installed across the pipe lines to get the system clean.

Additional flushing was necessary to get rid of the rust and corrosion – flushed out through the toilet.

Result

Pressure in the system back to normal – toilets can be used

